

# Multiblindo Easy

Istruzioni di montaggio  
 Assembling instructions  
 Instructions de montage  
 Montageanleitung  
 Instrucciones para el montaje

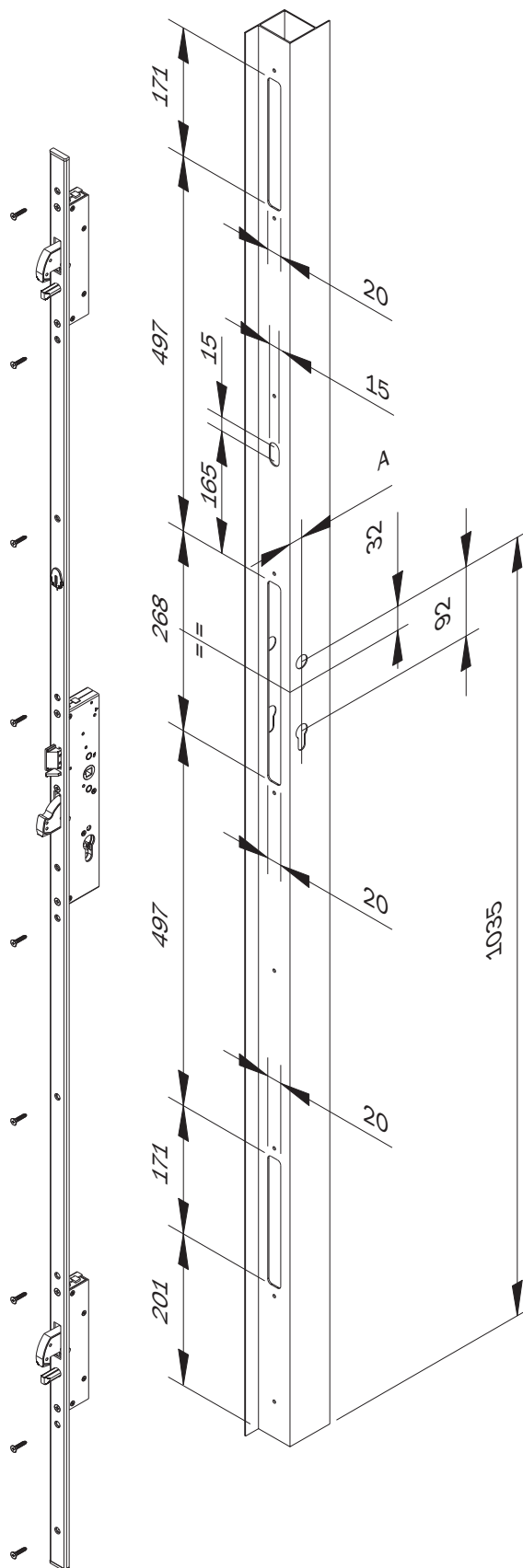

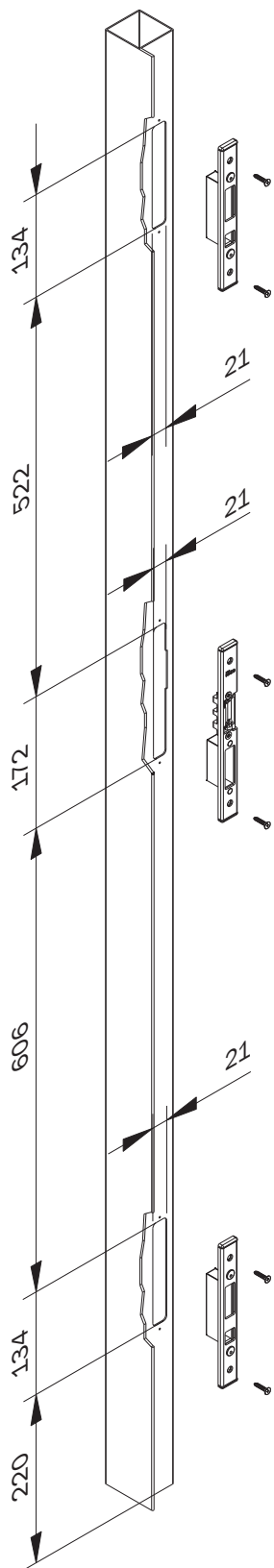
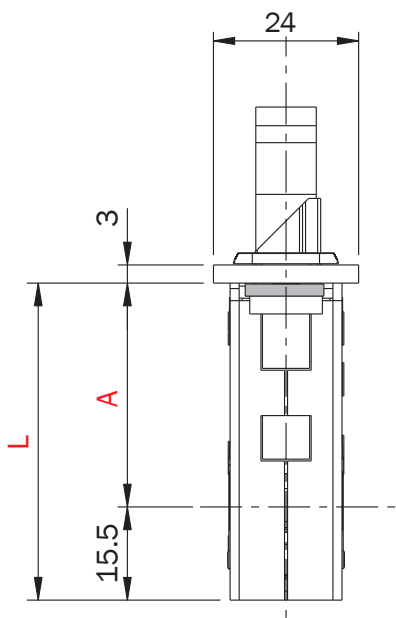

Cod.	E	A	L
7A3210352.*	35	32	47.5
7A3210402.*	40	37	52.5
7A3210452.*	45	42	57.5
7A3210502.*	50	47	62.5
7A3210552.*	55	52	67.5
7A3210602.*	60	57	72.5
7A3210652.*	65	62	77.5

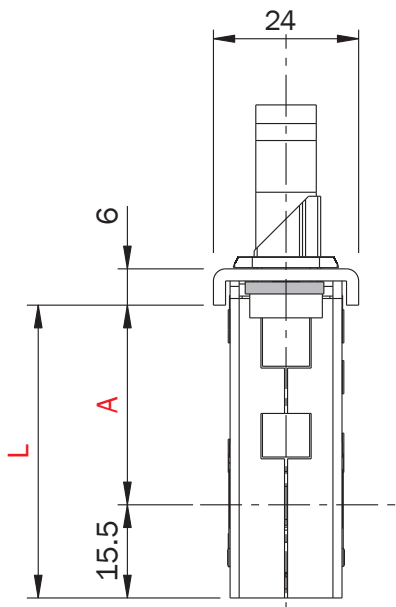

Cod.	E	A	L
7A320*352.*	34	28	43.5
7A320*402.*	39	33	48.5
7A320*452.*	44	38	53.5
7A320*502.*	49	43	58.5
7A320*552.*	54	48	63.5
7A320*602.*	59	53	68.5
7A320*652.*	64	58	73.5

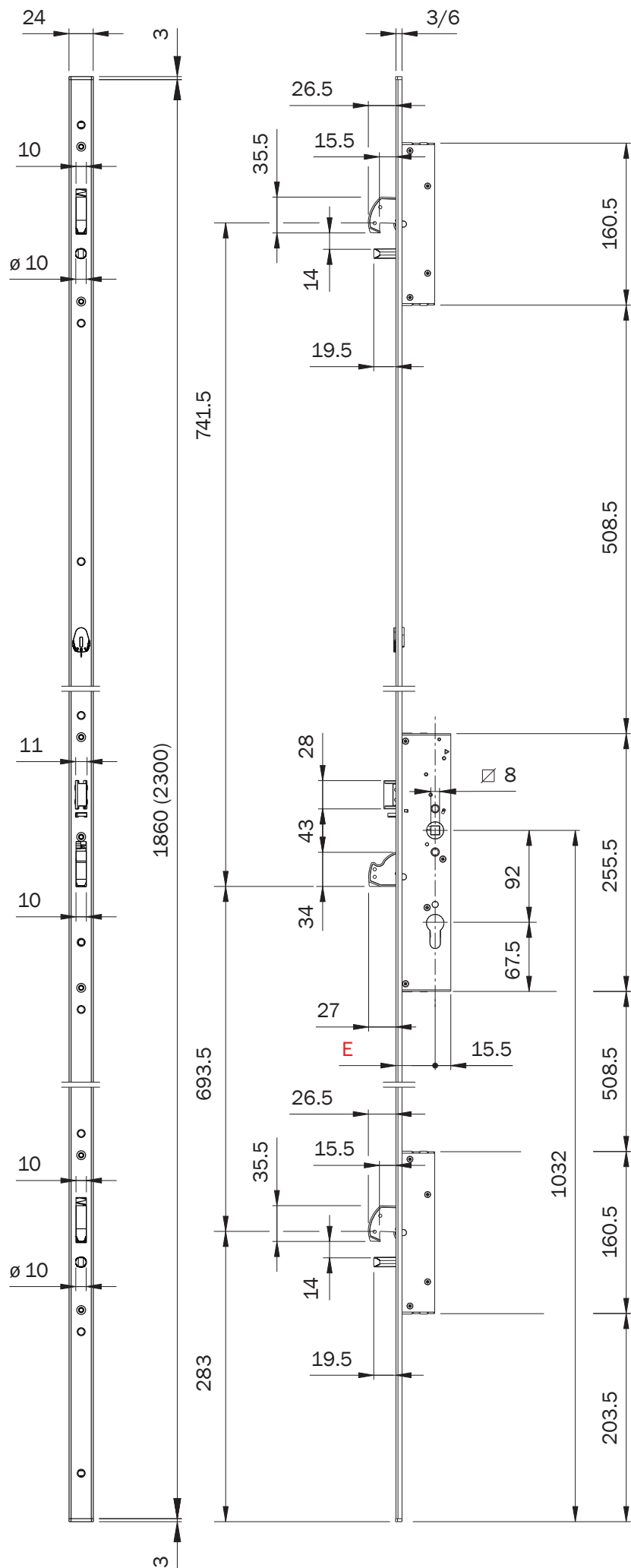

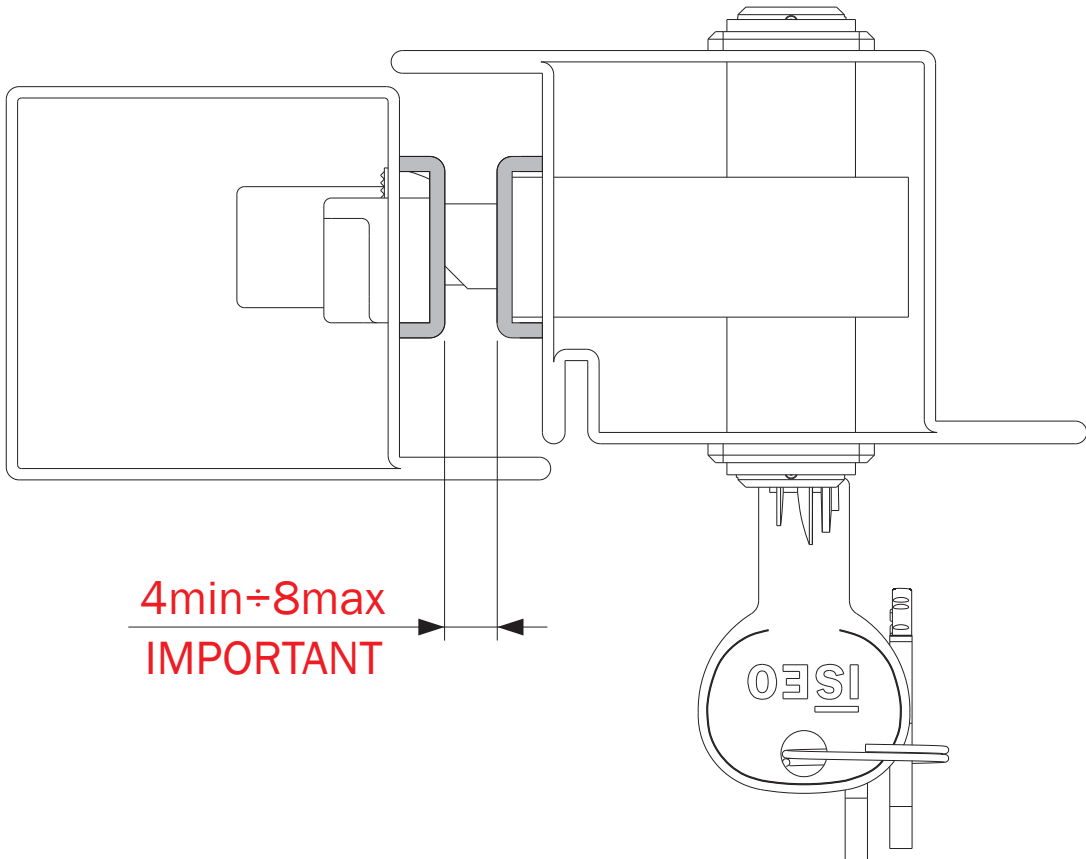
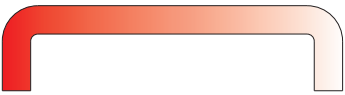
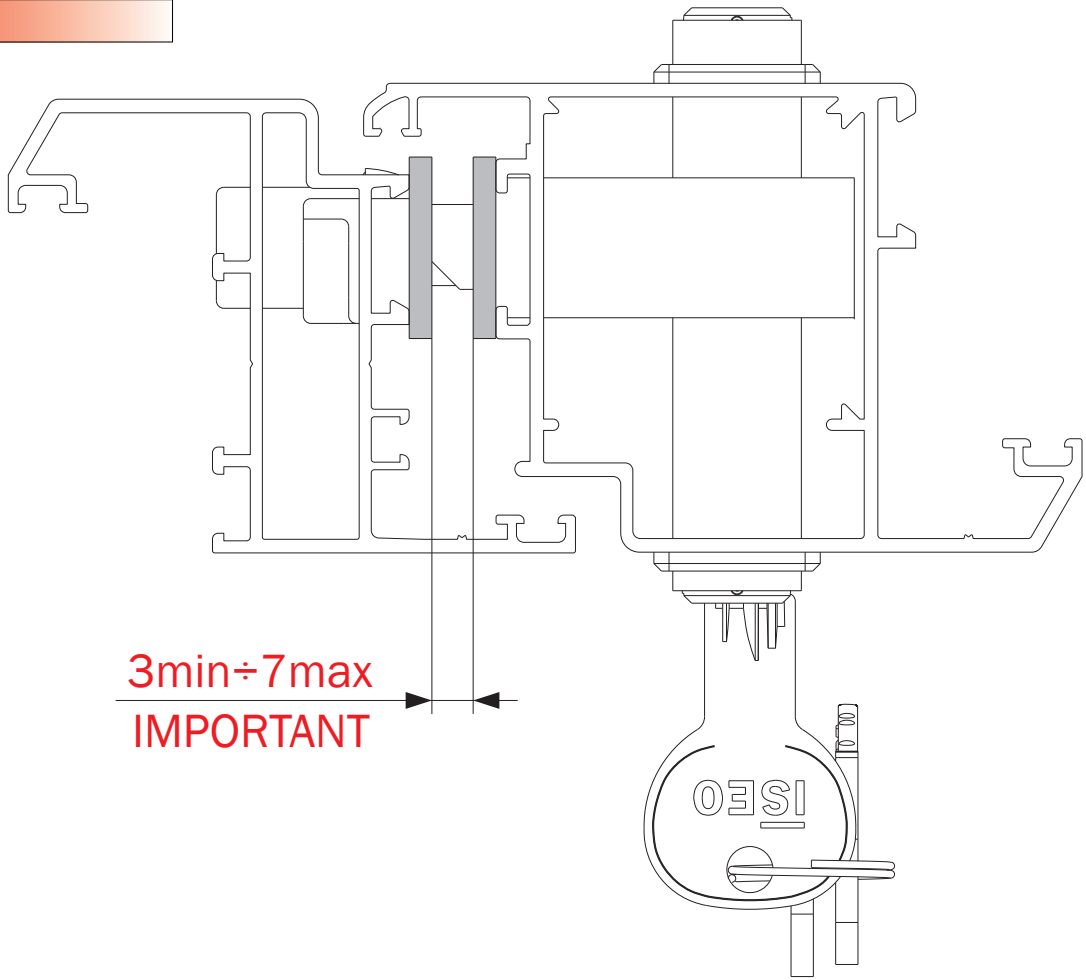

# TOTAL "0"

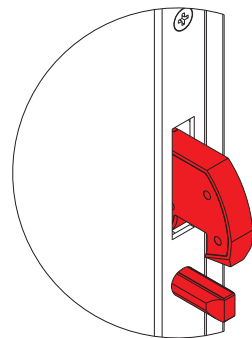
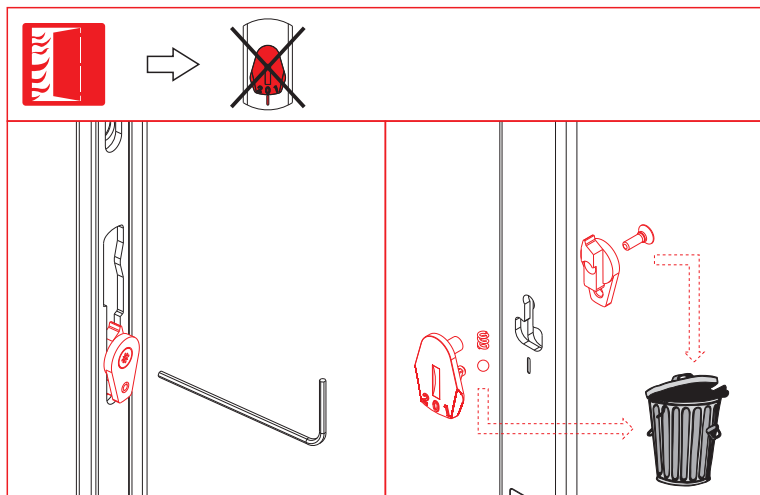
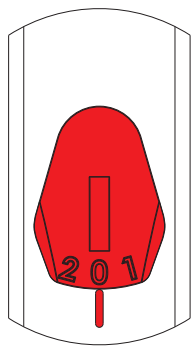

**AUTOMATIC LOCK**

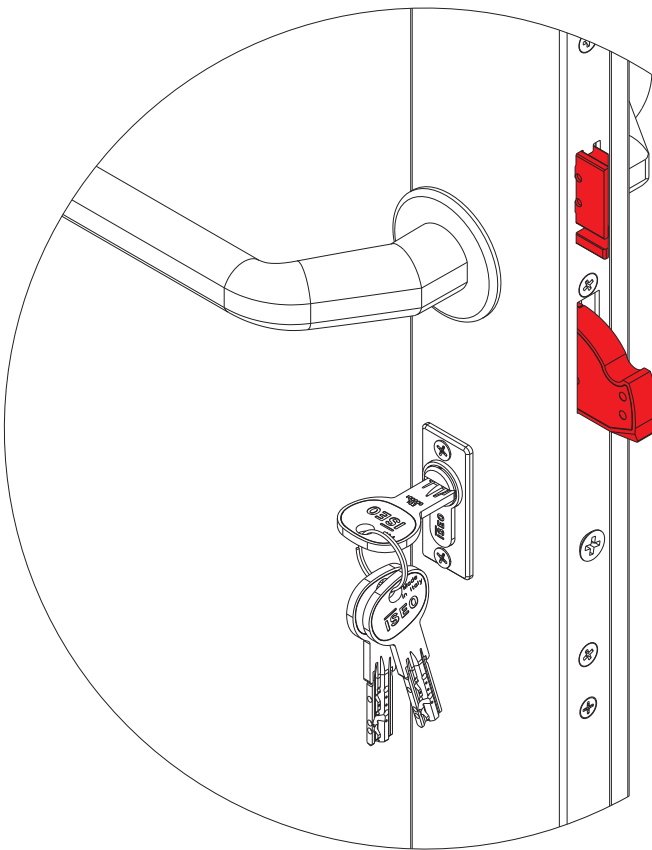
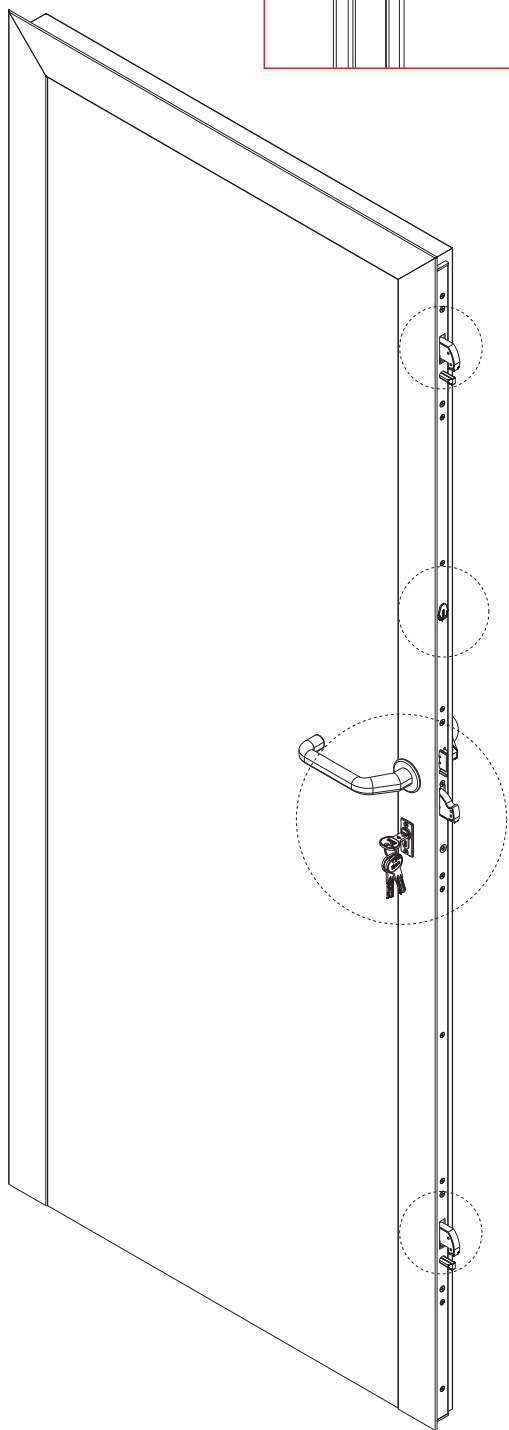
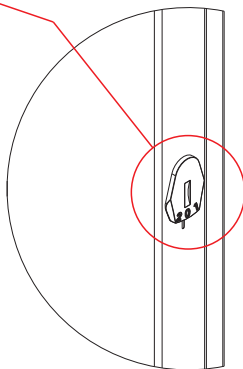

**AUTOMATIC LOCK**

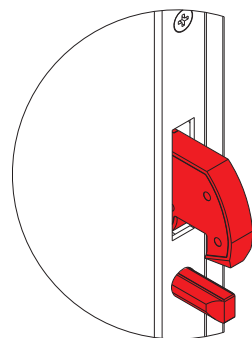

**AUTOMATIC LOCK**

# LIGHT "1"

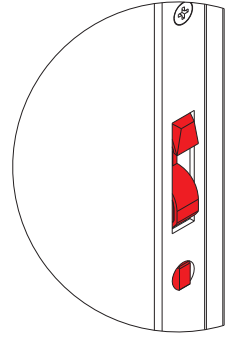
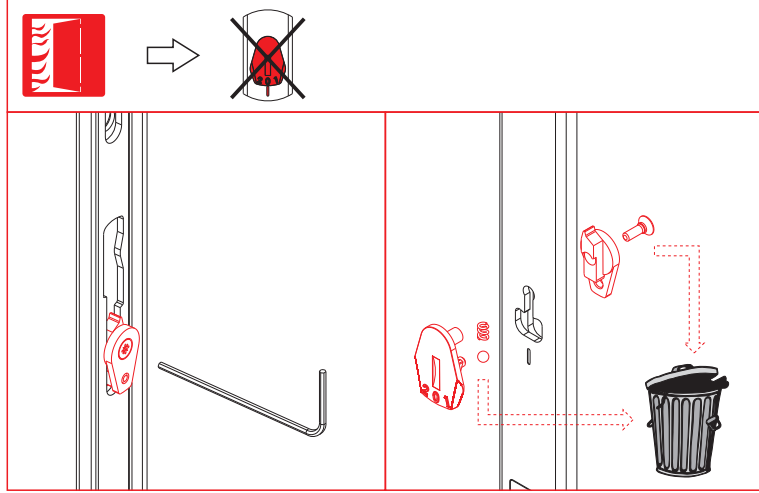
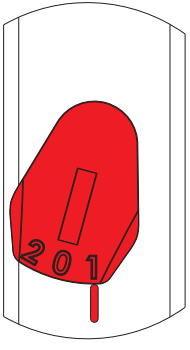

**HOOK LOCKED**

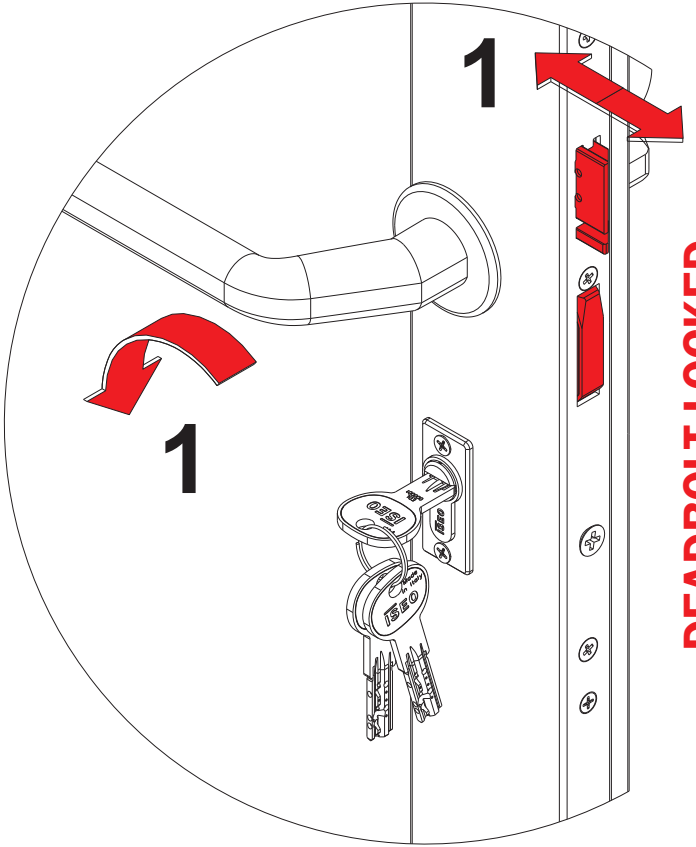
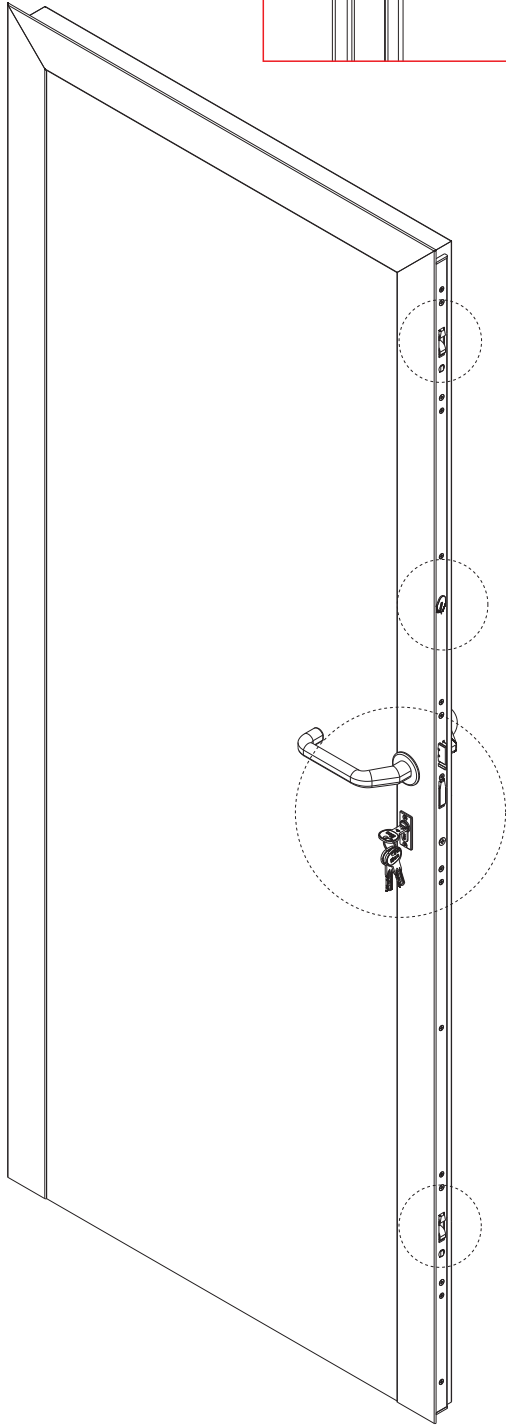
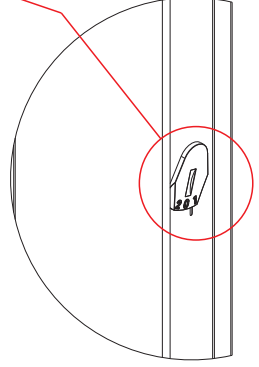

**DEADBOLT LOCKED**

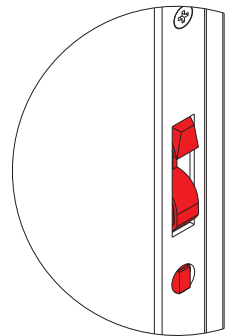

**HOOK LOCKED**

# FREE "2"

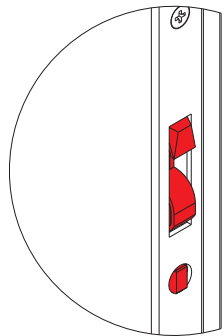
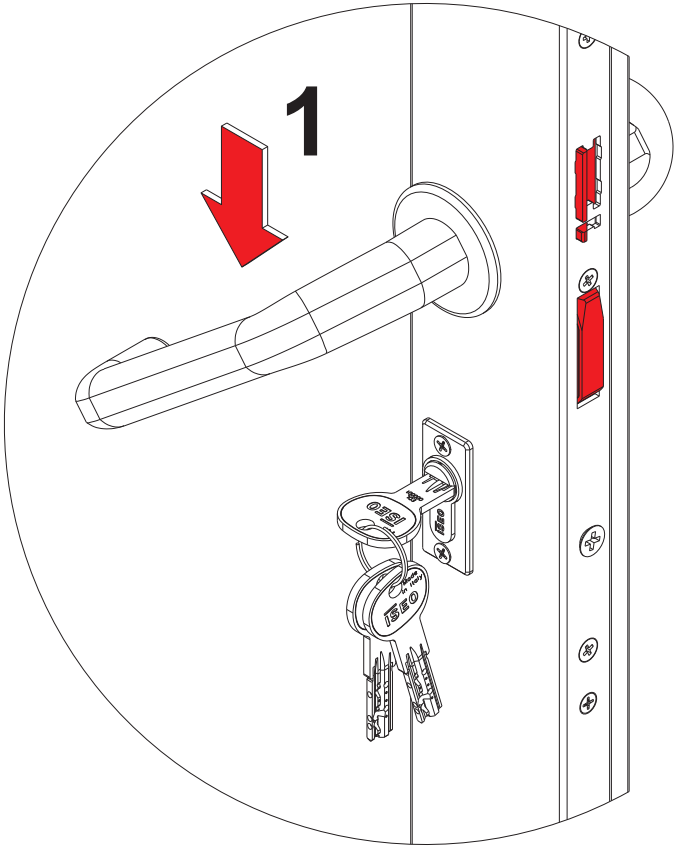
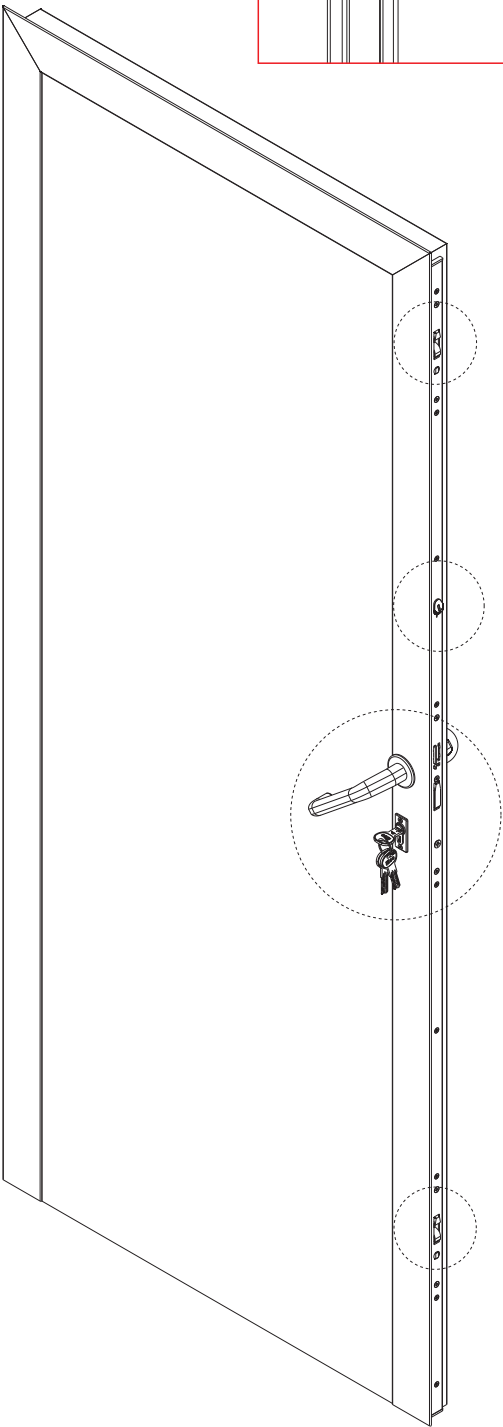
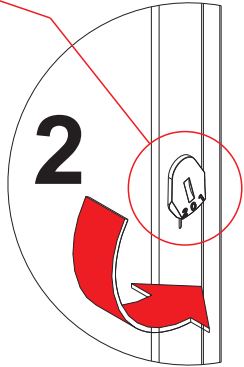
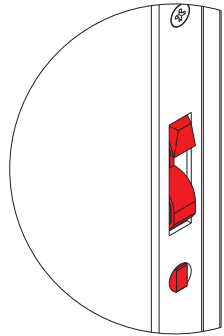
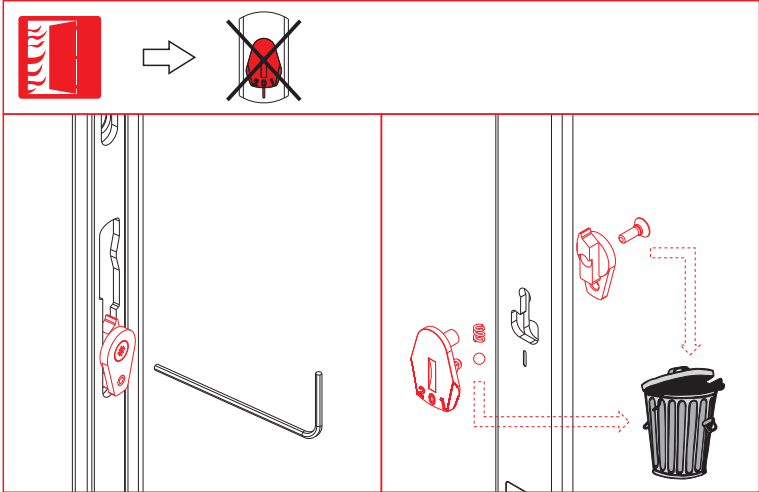
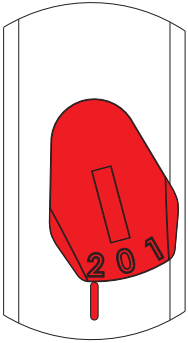

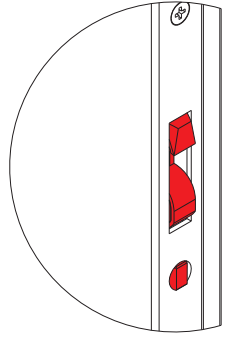
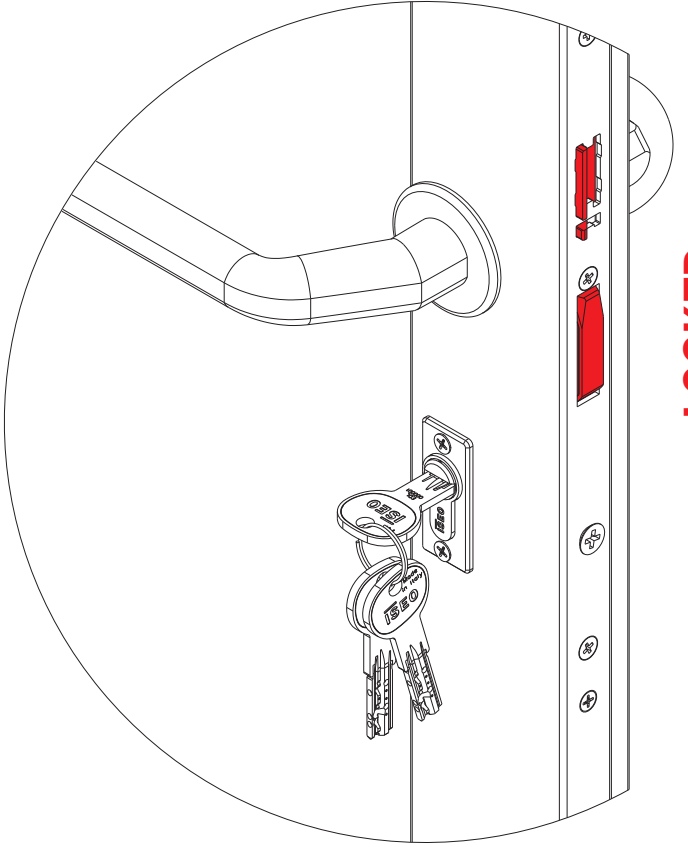
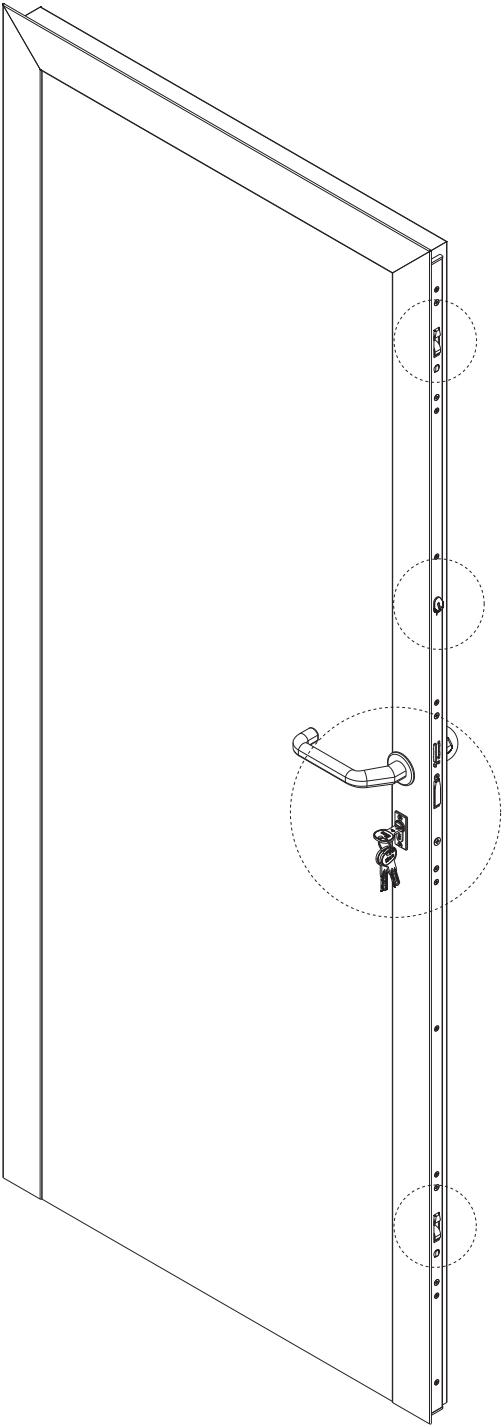

**LOCKED**

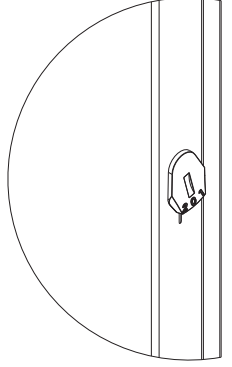

**LOCKED**

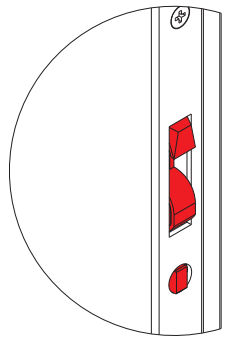

**LOCKED**



**ISEO®****Lock without extension for single leaf:**

prEN15685:2022 | 3 | X | 9 | B | 0 | G | 7 | 0 | 3 | 0 |

**Lock plus extensions (single or active plus semi-fix leaf) and/or****Lock without extension for double leaves (active plus semi-fix):**

prEN15685:2022 | 3 | X | 6 | A | 0 | F | 7 | 0 | 3 | 0 |

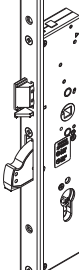
Sicurezza dei beni per i punti di chiusura e anti-separazione.  
 Security of locking points and separation points  
 Sécurité des points de fermeture et anti-séparation  
 Sicherheit für Schließpunkte und die Einbruchschutzpunkte  
 Seguridad para puntos de cierre y antiseparación

	<b>3</b>
	<b>7</b>
	<b>3</b>

il grado 7 si ottiene con una piastra antitrapano o con un adeguata protezione inglobata nella porta stessa.  
*Grade 7 is achieved with a drill-proof plate or a suitable guard built into the door itself.*

La classe 7 est obtenue grâce à une plaque anti-perçage ou à un dispositif de protection approprié intégré à la porte elle-même.

Güteklasse 7 wird mit einer aufbohrsicheren Platte oder einem geeigneten, in die Tür selbst eingebauten Schutz erreicht.

El grado 7 se consigue con una placa antitaladro o una protección adecuada integrada en la propia puerta.



**Configurazioni certificate**  
**Certified configurations**  
**Configurations certifiées**  
**Zertifizierte Konfigurationen**  
**Configuraciones certificadas**